

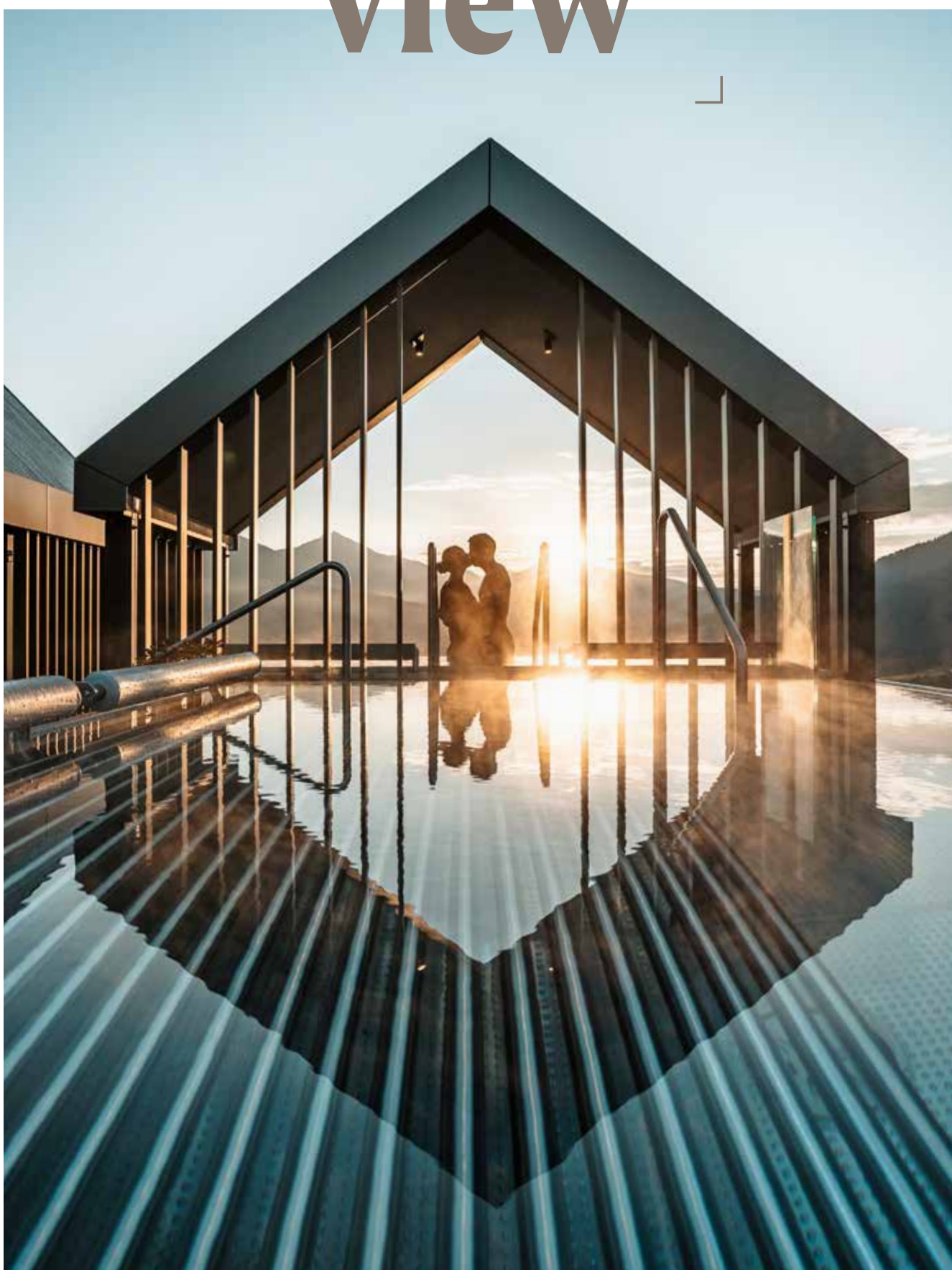

H U B E R T U S

view



VOL. 04 | 2026/27 FOR LOVERS OF SOUTH TYROL

ENG



A place where you
can stay awhile,
breathe in and appreciate
the happiness
of the moment.



Fam. Gasser

CONTENTS

Breathtaking scenery — 10
PANORAMIC TERRACE WITH SPECTACULAR VIEWS

A chance that became a passion — 14
CHEF DE CUISINE ANTONINO TRISCARI



Böckl (hi)stories from Geiselsberg — 18

Tracks in the snow, fire in the heart — 22

How the Böckl achieved worldwide fame — 24

An entrepreneur with passion and vision — 28

Wellness between blue skies and comfort — 33

A life between forests, mountain pastures and well-being — 40
SONJA, THE REFRESHING SOUL OF THE HUBERTUS

A workplace above the clouds — 44
THINA ADAMS, DIRECTOR OF THE LUMEN MUSEUM

A region that will move you — 46
EXPLORING THE PUSTERTAL VALLEY ON TWO WHEELS



Hubertus View — VOL. 4
ANNUAL MAGAZINE 2026/27

Gasser Touristik GmbH
The Gasser Family · Furkelstrasse 5
I-39030 Geiselsberg-Olang
Tel. +39 0474 592 104
info@hotel-hubertus.com
www.hotel-hubertus.com
CIN: IT021106A1Z27AP6LF

EDITOR Arnold Kaser
DESIGN Dialog GmbH – Verena Fischnaller
PRINTED BY Dialog GmbH
ILLUSTRATIONS Dialog GmbH – Vivien Mitterutzner, Irene Plank

PHOTOS Dialog GmbH – Vivien Mitterutzner, Manuel Kottersteger, Archive: Gasser Family, Olang Tourism Office (Alex Moling), Lukas Schnarf (article Geile Böcke)

TEXTS Arnold Kaser; other texts – Nadia Mahlknecht

TRANSLATIONS Bonetti & Peroni, Bozen

OUR THANKS FOR THEIR SUPPORT GOES TO Franz Steger, Josef Töchterle, René Töchterle, Thina Adams, Pepi Moser, Werner Schönhuber, Lukas Schnarf.

Article on Böckl Hubertus VIEW+: source: Kuno Prey, Sarah Troi, "s'PÖCKL – Tradition Handicraft Sporting Spirit" (Faculty of Design and Art, Free University of Bozen/Bolzano) in collaboration with Ivh.apa (Trade Association for Craftspeople and Service Providers).

PUBLISHER Dialog GmbH
www.dialog.bz

ENVIRONMENTAL AWARENESS

This magazine was printed by Dialog GmbH using 100% solar energy on a net basis. The paper used is FSC-certified. The print technology used is also exceptionally resource-efficient.

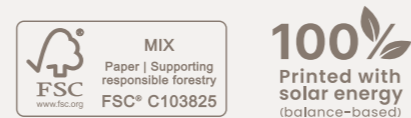

Dear guests and friends of the Hubertus,



it is often only when something familiar returns that we realise just how quickly time has passed. This is also true of our Hubertus View magazine: no sooner has one issue been published than new thoughts and ideas for the next begin to emerge. We are delighted that this magazine has now established itself as an integral part of the Hubertus experience. The aim of each issue is more than merely to inform: we offer insights into the everyday life of our hotel and the people who dedicate themselves wholeheartedly to making sure that our guests feel at home. We will be presenting some of our staff in greater detail in these pages. At the same time, we take a look at our surroundings, recalling stories from the past and memories that are worth preserving. This issue is also intended as a small tribute to previous generations. In keeping with tradition, we dedicate part of the magazine to our family history, in gratitude to those whose work and vision have laid the foundations for the Hubertus as it is today. Up-to-date impressions and news from the Hubertus can of course also be found in this issue. We wish you happy reading!

With kindest regards,
Your hosts
Daniela and Markus Gasser



PEACE, DISTANCE
AND WINTER ENJOYMENT
AT ITS FINEST.

Swimming with views of
the valley and the snow-
covered mountains.



**PANORAMIC POOL,
PEACEFUL ATMOSPHERE.**

Large glass surfaces open onto the outside world while separating the spacious relaxation area: swim in soothing silence.



HEAVENLY, HELLISH, UNIQUE.

The spectacular Heaven & Hell wellness platform floats high above the valley, between heaven and earth: panoramic views of the Dolomites merge with an exclusive sauna and hot tub experience in an architectural gem that redefines wellness.

Breathtaking scenery

PANORAMIC TERRACE WITH SPECTACULAR VIEWS



Dining with a view in an atmosphere that moves the soul, awakens the emotions and transforms a holiday into a holistic experience.

Here, the view opens onto mountains, light and sky, to produce a backdrop that gently pushes the everyday into the background, allowing space to savour the moment.

The view is more than just a panorama, it is a natural companion for your stay. From the dining room, where every meal is a delight for each and every one of the senses; to the terrace, where you can enjoy an aperitif and linger in the sunshine. Interior and exterior both open up to the landscape, with architecture and furnishings deliberately given a back seat. The result: a place where you can feel the vastness, where you can arrive, take a deep breath and stay awhile.

DINING AT ITS FINEST

From breakfast through to dinner, there are culinary delights to accompany your day in style. Regional ingredients and elegant touches turn every meal into a moment for conscious enjoyment.

< Ample space, soothing tranquillity and a relaxing atmosphere: a place where the feeling of freedom becomes second nature.



A treat for the eyes and the palate: Alpine-Mediterranean sophistication as a delicious taste of happiness.



Pâtisserie chef Alessia takes passionate care of the sweet delicacies she makes.

A sweet touch, a careful artistry

The sweet delicacies created here combine passion and craftsmanship. In the patisserie, attention to detail and a keen sense of taste guide the careful selection of ingredients as they take form, step by step. Every move is precise; every ingredient finds its place. This dedication is particularly evident in the work of Alessia and her patisserie team. Their calm, experience and creativity create desserts that are more than just sweet treats: each becomes a silent moment packed with flavour and sensuality.



Carefully prepared and harmoniously arranged, each dish combines delicate flavours with sensitivity and precision.



Craftsmanship you can taste: fresh apples and quality ingredients are lovingly transformed into the classic apple strudel.

RECIPE FOR ORIGINAL SOUTH TYROLEAN APPLE STRUDEL WITH SHORTCRUST PASTRY

INGREDIENTS

DOUGH: 125 g butter, 125 g icing or normal sugar, 1 pinch grated lemon zest, ½ packet vanilla sugar, 1 tbsp milk, 1 egg, 250 g flour, 1 tsp baking powder

FILLING: ½ tsp cinnamon, 1 pinch salt, 600 g apples, 50 g sugar, 50 g breadcrumbs (toasted in a little butter), 40 g raisins, 20 g pine nuts, 2 tbsp rum, 1 packet vanilla sugar, 1 pinch grated lemon zest, egg for brushing, icing sugar for sprinkling

PREPARATION

DOUGH: mix the butter (not too cold) with the sugar, lemon zest and vanilla sugar. Add egg and milk, then mix. Add the flour and baking powder and knead everything into a dough. Leave to rest for 30 minutes.

FILLING: cut the peeled and cored apples into small slices. Mix sugar, breadcrumbs, raisins, pine nuts, rum, vanilla sugar, cinnamon and lemon zest with the apples.

PREPARING: roll out the dough to approx. 40 x 20 cm and place on a buttered baking tray. Spread the filling on the dough and fold over. Brush with beaten egg.

BAKING: Bake at 180 degrees for 35 minutes. Allow to cool, then sprinkle with icing sugar.





A chance that became a passion



A journey may only mean crossing continents, but can also begin in one's homeland. Before he set out to discover the world, Antonino Triscari started out in a small village in northern Sicily; a place full of sunshine and stories that would shape him forever.

< Chef de cuisine Antonino Triscari combines Mediterranean lightness with Alpine traditions, taking the best of each world.

It is a hot summer's day in Sicily, with the sun beating down on the narrow streets of San Fratello, a small village of 3,000 people in the north of the island. This is where, on 7 January 1987, Antonino Triscari was born. He spent his early years far from home: when he was barely a year old, he moved with his parents to New York where his father ran a building company. Until his tenth year, Antonino grew up amid the hustle and bustle of the metropolis: skyscrapers, car horns, the flashing lights of countless neon signs. After this exciting period, he and his family moved back to their Sicilian homeland. The change was a minor culture shock for Antonino – from a vibrant, cosmopolitan city to a tranquil village in Sicily, where time passes differently.

By chance into the kitchen

His path to the kitchen was never planned, but rather a matter of chance. As a boy, Antonino worked evenings to earn some extra money as a waiter in a restaurant. One evening, the restaurant owner asked him to help out in the kitchen. The request came without warning, but it changed a great deal. The guests were delighted, because he worked well with the chef and the results were impressive. Antonino all of a sudden knew, without being able to phrase it in words: "This is the path for me."

“Cook as if you were cooking for yourself!”



Passionate down to the last detail: each plate is a miniature work of art, enthusiastically created.

Learning by doing

Antonino did not go to vocational school: he learned by doing. At the age of 17, he attended an advanced course in Rome, working without pay in a five-star hotel and absorbing everything: techniques, procedures and the quiet concentration behind the shiny pots and pans. But even more formative was the time spent on the island of Ischia, at the Terme Manzi Hotel & Spa. Chef Nino di Costanzo, holder of two Michelin stars, taught him that precision and passion are not opposites, but rather mutually dependent. Every movement, every spice, every aspect had to be just right. “This way of thinking and working has shaped me more than any other experience to this day.”

Simple and sophisticated

Today, Antonino describes his style of cooking: “Simple and sometimes sophisticated.” This unassuming expression encapsulates his entire professional experience: reduction to the essentials, little touches, respect for the product. He always gives his team the same advice: “Cook as if you were cooking for yourself.” His dishes are marked by their strong character, with flavours that are both powerful and elegant. In his private life Antonino opts for a simple lifestyle, however: salads, occasional meat dishes, regional produce.

Green cuisine

This is a philosophy that goes far beyond taste: “When you cook with regional ingredients, you not only support farmers and small businesses, you also often get significantly better quality.” For him, sustainability is no mere buzzword, but a fundamental part of everyday life. Antonino talks about purchasing planning, waste prevention and reusing leftovers. “Sometimes I’ve had heated discussions with my team”, he says, “but, when you explain the reasoning behind each step, it often leads to something good.”

Memories and inspiration

When asked about a dish from his childhood, he answers without hesitation: “Carbonara”. A dish that has stayed with him to this day: simple, hearty and honest. He does not identify any great role models, because Antonino admires all those in the restaurant trade who strive every day to do their best and work with passion. He finds inspiration everywhere: in new ingredients, in techniques, but also in his family: his two children, Alfio and Matilde, and his wife Deborah. Working in the kitchen demands a great deal of commitment, but the desire to be a good father and partner remains his driving force. His work means that time spent together is precious, so he makes conscious and devoted use of it.

What can guests expect from him? “We prepare the ingredients in the best possible way and we want good food to bring people joy.” Joy in eating and a kitchen full of team spirit, where humour is just as important as salt. Respect is vital; workplace harmony is essential. “The job is challenging, but laughter is a must.”

For Antonino Triscari, cooking has to combine a down-to-earth approach with precision. His journey shows that passion can often begin by chance, then takes form through consistency and attitude. Guests can be sure that food here is cooked to produce joy, where every plate tells a story of passion, precision and taste.

HUBERTUS view+

18

BÖCKL (HI)STORIES FROM GEISELSBERG

The people of Geiselsberg talk about the past, their childhood, the long winters and the simple life. The Böckl was their companion, playmate – and only means of transport.



22

TRACKS IN THE SNOW, FIRE IN THE HEART

A tight-knit group who found freedom, passion and a special attitude to life in Böckl riding: the legend of the “Geilen Böcke” team and memories of the 1990s.

24

HOW THE BÖCKL ACHIEVED WORLDWIDE FAME

The Böckl of Geiselsberg and similar contraptions around the world. A tradition that remains particularly strong in Geiselsberg to this day: from a simple wooden device to a fine-tuned racing machine.



28

AN ENTREPRENEUR WITH PASSION AND VISION

Our grandfather Franz: an entrepreneur with passion and vision. From car dealer to co-creator of the Kronplatz. A life's work in the service of both people and region.



Böckl (hi)stories

from Geiselsberg -
a living winter tradition

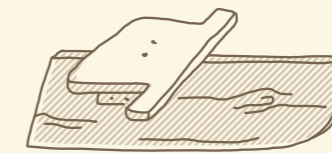
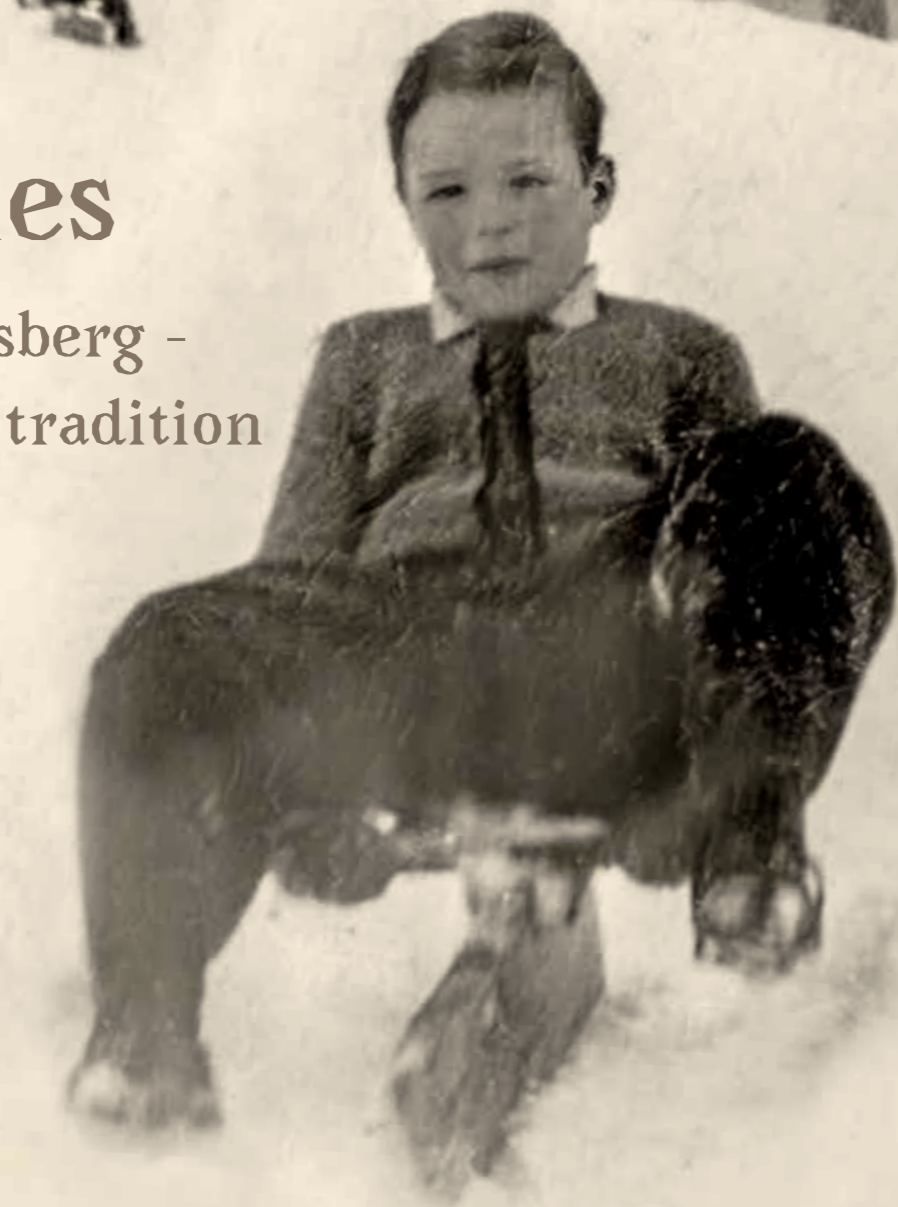

Geiselsberg has always been closely associated with a simple, uncomplicated device used for winter sports. It once consisted of a runner with a simple flat seat attached. It was originally created for having fun in the snow during the long, cold winters, and as a practical form of transport for the children of the mountain farmers: over the years, it has been continuously developed, with the runner now replaced by a ski and with a padded, leather-covered seat. It is still steered by shifting one's weight and braking with the feet.

Some of the people of Geiselsberg can tell very personal childhood stories of growing up with the "Böckl", as they affectionately called it. These stories are closely entwined with Geiselsberg and the simple life high up in the mountains.

The exact origins of the Böckl remain unclear to this day: it was probably developed almost simultaneously in various forms in different places around the world. Nevertheless, many stories about the Böckl are closely connected to Geiselsberg and, even today, almost every family still has one.

The Böckl is a reminder of a time when people used simple means, a bit of skill and some common sense to make everything for themselves: from their tools to the toys that characterised their spartan lives up in the mountains.

The Böckl represented the inventive spirit of the mountain people and was more than a mere form of transport for the children of that time: people would get by with very little in those days and the simple things were often the most valuable. René Töchterle from Geiselsberg describes it particularly well: "My father built my first Böckl when I was a child. It was simple, made from a few pieces of wood, yet it meant the world to me. For years I raced down the slopes on it. Today, it fills me with joy and also a little melancholy when I see my children discovering the Böckl for themselves."

Almost every family today still has a Böckl.

< Franz Steger, a Geiselsberg original. A rare photograph from the 1950s: as a little boy on the Böckl, from a time when people got by with little and happiness lay in riding the Böckl.

A childhood up in the mountains

Franz Steger, born in 1950, fondly remembers his childhood up on the farm. In a strong, clear voice, he recounts what it was like back then.

"I grew up on the Mittereggerhof farm, at an altitude of 1,500 metres, one of the highest mountain farms in Geiselsberg. There were nine of us children, five girls and four boys. Large families were seen as normal back then."

My childhood was marked by strictness and frugality, but also by a great sense of security. It was a childhood spent without luxury, but with plenty of freedom.

"We did not have much, but it was enough. Everything we needed to survive was grown, harvested or produced on the farm. We were mainly self-sufficient, so to speak: we only had to buy salt and sugar."

The way to school led from the farm down to the village: six times a week, early in the morning, in all weathers. Before lessons began, school mass was celebrated.

"We children always walked and the winter was the hardest. In the early morning we would trudge down the valley in the cold and dark, often with fresh snow lying deep on the narrow footpath."

The school was down in the village, right next to the church. "It was a small school with several age groups in each class, a so-called mini school. While one group worked on their own, the teacher would take care of the younger ones. This demanded discipline but also made us independent.

Several siblings often sat next to one another in the same class." When everyday life came to a standstill for a moment on our free Sundays, we children would spend the time making our own toys. "One day, some of my siblings sawed off a thick board, about 30 centimetres long and rounded at the front. They nailed another board on top of it to sit on. The first test run went surprisingly well. They enthusiastically at once built a second one and, the following Monday morning, we ventured down the steep footpath to school. The Böckl was as if made for it. We whizzed downhill, faster than we had even thought, down the partly icy route." But, as soon as we got to school, our euphoria gave way to a touch of uncertainty. "We hid the Böckl under a tree because we thought the other children would laugh at us for riding it. But nothing stays hidden for long in a small

mountain village. The next day our secret was out, and word soon got around that there was now a new, fast way to get to school." Those who came to school on the Böckl were wide awake in the morning, with red cheeks and fingers all wet, but filled with that little bit of freedom that always transformed the snowy journey to school into a mini-adventure.



It is our memories that now let us see how much simpler – and perhaps better – things used to be.

The holy water and the Böckl



Josef Töchterle, born in 1952, from Gassl/Geiselsberg, recalls a very special Böckl run from his childhood.

It was around Epiphany on a clear, freezing cold winter morning. Back then, holy water was obligatory in every household. It was our deeply held belief that, before leaving the house, you had to make the sign of the cross and sprinkle holy water on your forehead in the hope that you would return safely. My job that day was to go up to the church in Geiselsberg to fetch more holy water and, to speed my return, I took my Böckl with me. With a small tin jug filled with holy water in my hand and the Böckl under me, I whizzed down the well-worn path. But the water sloshed around so much that I arrived home with an empty jug: I had no choice but to climb all the way back up to the church. Learning from this experience, I rode down more carefully this time and, sure enough, arrived home with a jug full of holy water. A minor episode from another time – yet so typical of a happy childhood.



What began as a simple fun way to ride and a practical means of transport subsequently became an item of sports equipment once the idea of organising the first races arose.

From that point on people would experiment, upgrade and tinker, as now it was no longer merely a question of fun, but also a matter of honour: who was fastest, and who could build the fastest Böckl? In the 1950s, up to 80 participants would appear at the starting line, cheered on by the children, with fathers full of pride, and mothers warning the racers to be careful. Timekeeping was simple but reliable with two synchronised stopwatches, one at the start and one at the finish. Races started fairly and precisely at one-minute intervals. Great ingenuity was soon evident in the choice of materials: "My father", recalls Josef Töchterle, "cut the wood to size, while the iron runners were nailed on by the blacksmith in Niederolang. If you could afford it, you chose runners made of sawblade steel – unbeatably fast but very expensive." The races soon became a firm favourite, livening up the quiet winter days. Some competitors might fall, some won, of course, but the stories written in the snow back then remain in the memory to this day.

The postman from Naples

One of the oldest stories dates back to the 1940s.

A postman from Naples, who had to cover the route from Olang up to Geiselsberg, was looking for a solution to ease the steep return journey. It is said that the toboggan maker J. Sapelza from Oberolang made for him a special vehicle, smaller and lighter than a conventional toboggan, that was stable and manoeuvrable enough to run safely down to the valley. The story of the postman from southern Italy and his ride is still told as one of the earliest adventures that made the Böckl what it means to Geiselsberg today.



When the path to Geiselsberg becomes a racetrack

What began as a simple fun way to ride and a practical means of transport subsequently became an item of sports equipment once the idea of organising the first races arose.

From that point on people would experiment, upgrade and tinker, as now it was no longer merely a question of fun, but also a matter of honour: who was fastest, and who could build the fastest Böckl? In the 1950s, up to 80 participants would appear at the starting line, cheered on by the children, with fathers full of pride, and mothers warning the racers to be careful. Timekeeping was simple but reliable with two synchronised stopwatches, one at the start and one at the finish. Races started fairly and precisely at one-minute intervals. Great ingenuity was soon evident in the choice of materials: "My father", recalls Josef Töchterle, "cut the wood to size, while the iron runners were nailed on by the blacksmith in Niederolang. If you could afford it, you chose runners made of sawblade steel – unbeatably fast but very expensive." The races soon became a firm favourite, livening up the quiet winter days. Some competitors might fall, some won, of course, but the stories written in the snow back then remain in the memory to this day.

Tracks in the snow, fire in the heart

The legend of the Geilen Böcke



Together on the road to adventure: with the Böckl as a faithful companion



Courage, balance and skill: the only way to succeed at Böckl racing with skilful turns in the snow



On high: daring jumps at unforgettable freestyle shows

In the 1990s the leisure activities of certain young people took an exciting turn. Driven by a desire for freedom and adventure, a new, less conformist attitude to life developed. The “Rennböckl”, a type of sports equipment that had fallen out of favour, was restored to its original purpose – racing. The youngsters founded a club, “Die Geilen Böcke” (The Cool Goats), that could hardly have been more aptly named, as what they achieved is still remembered today.

In the early 1990s, a group of young people came together in Olang, united by a shared passion: Böckl riding. What began as a casual get-together quickly developed into a close-knit community. Its members chose a name that left no room for doubt: the “Geilen Böcke” (the Cool Goats). A mixture of enthusiasm, self-irony and zeitgeist, it would have been hard to find a more apt name for this era. The group’s appearance was unmistakable from the outset: a one-piece, jet-black racing suit made of synthetic leather that became their trademark. Striking, uncompromising and soon as legendary as the group itself. Rumours persist to this day that they often wore nothing else underneath.

After long winter days outdoors, the action regularly shifted to après-ski. There was laughter, fooling around and partying, often lasting much longer than the day on the slopes. Their outfit also proved to be surprisingly suitable for everyday use away from the snow. Sticky drinks simply ran off it, while care could not have been easier: garden hose, water, done. What began as a local passion soon attracted attention beyond South Tyrol. At freestyle shows, the Geilen Böcke demonstrated what was possible with their Rennböckl. Daring jumps, acrobatic tricks, spectacular runs. The performances became crowd-pullers and the group became an integral part of this special scene. Not every story needs to be told. What remains is a legendary, slightly wild attitude to life that is still remembered today.



Böckl World Championships on Kronplatz

The word spread: inspired by the Olang Böckl Club, new groups formed in neighbouring villages. Races were organised, events held, and Böckl riding gained momentum. Step by step, a movement was developing from a leisure activity. The next highlight came in 2005: together with Amateursport Olang, the Geilen Böcke organised the first “Bock World Championships” on Kronplatz. Over two hundred participants from six nations came together to compete on their Böckl. Another world championship was to follow in 2013. These two events developed into friendly gatherings of like-minded people, where the focus was not just on competition, but above all on the shared enjoyment of this unusual traditional piece of sports equipment and the enthusiasm for Böckl riding.



Crazy heroes of freestyle shows. Brave and unpredictable!



How the Böckl achieved worldwide fame

From wooden board to racing machine

What once began as a simple board seat on a runner has seen astonishing development over the years. The Böckl was modified, put together and tested until it became a true racing machine. These Böckl were tuned, with suspension added and aluminium and stainless steel used instead of wood. Each had its own design and colour, with laser-engraved lettering and images, original Harley Davidson parts added, leather seats fitted, etc. etc. The youth of Olang came up with endless ideas for their Böckl: instead of iron runners, skis were screwed on – first old, discarded ones, later modern carving skis. A direct comparison quickly revealed the potential of these unusual vehicles: in a speed test against a professional downhill skier, a Böckl rider reached an impressive 140 kilometres per hour, just behind the expert on his racing skis. What was once a simple wooden contraption had thus become a true racing machine.

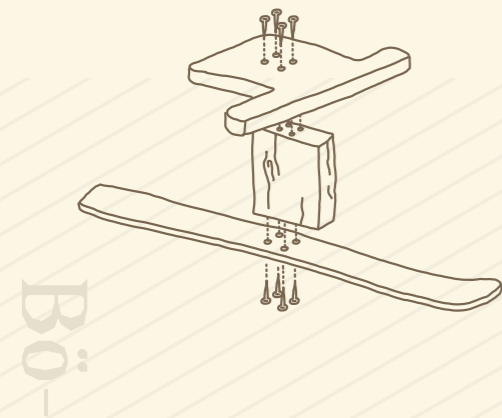

WHERE DOES THE NAME "BÖCKL" COME FROM?

In South Tyrolean dialect the word Böckl is often spelled with a "P" – Pöckl. Replace the "P" with a "B" and the origin becomes clear: in Bavarian dialect, "Böckl" simply means "little goat". Originally, it referred to the seat on a cart or carriage where the driver would sit. So the term fits perfectly: a small seat on a runner, ready to head down the slopes. Today, the Böckl is no longer built out of necessity, but of passion. It is now part of the region's identity, a symbol of how the lives of mountain people were shaped through ingenuity and a sense of community. If you are in Geiselsberg on a winter's day, you may once again hear the shouts, the laughter, the scraping of runners in the snow – then you will understand why the Böckl is more than just a piece of winter sports equipment.

-ckl

THE ORIGINAL BÖCKL

Mountain farming families in the Pustertal Valley had little money but plenty of ingenuity. At some point, someone had the idea of building a simple sled using a wide board, a smaller board as a seat and a crossbar as a handle, with a narrow iron rail as a runner. This is how the original Böckl came about: simple, inexpensive and robust.



Original Böckl from the 1950s

THE SKI BÖCKL IN THE 1970s

In the 1970s the Böckl underwent a major development: rapid advances in the ski industry meant that new models were constantly coming onto the market, resulting in large numbers of old skis accumulating in many an attic. This produced a simple yet effective idea: instead of runners, skis were attached directly to the Böckl, thus ensuring better running and greater stability.



Ski Böckl from the 1970s

THE RACING BÖCKL FROM THE MID-1990s

In the mid-1990s, carving skis revolutionised skiing with their tapered shape. Instead of sliding, turns could now be made cleanly on the ski edges. Carving skis also gradually replaced the previous models used for the Böckl, making the racing models significantly more precise, more dynamic and faster. New materials were introduced at the same time, with wood often replaced by stainless steel and aluminium. Frames were customised with laser-engraved logos and images, while seats were covered with leather.



Racing Böckl from the 1990s

The Böckl in Geiselsberg and around the world

Over time, similar forms of transport have emerged in many regions of the world, made of wood: functional, handcrafted and using whatever other materials were available. These devices probably developed independently of one another and around the same time. A dedicated research project would be needed to establish their exact origins and parallels.

But the Böckl's connection to Geiselsberg is particularly special. Here, the Böckl is much more than just a way to get around in winter: for generations, it has been regarded as a vital symbol, a living tradition and an integral part of the village's identity and connection to its homeland.

Not for nothing is the Böckl from Geiselsberg also permitted as sports equipment on the ski slopes at Olang. The tradition is consciously carried on. In this way, a silent sign that living history is sometimes stronger than bans and that tradition can have a future.

SOUTH TYROL

GEISELSBERG: it is said that in the 1940s a postman used the first Böckl to deliver mail down into the valley. **AROUND THE SELLASTOCK:** the Ladins were supposedly inspired by the large rattles sounded on Good Friday in place of the silent church bells.

ITALY

PIEVE DI LIVINALLONGO: here, Böckl-like contraptions – “Lousin” – were made from naturally curved tree trunks: lightweight, portable and extremely practical.

GERMANY

The “Skiböckle” with a padded seat was developed in the Allgäu region and is also available as a kit.

AUSTRIA

The “Klumper” originated in Tulfes in the Stubai Valley. It is a variation of the Pustertal Valley Böckl that was adopted during a race there. It has a particularly thick board as its main body.

SWITZERLAND

Here, too, there are several variants of the Böckl. Two dedicated Böckl enthusiasts independently developed similar models called the “Ski-Gibel” and the “Ey-Schi”.

SLOVENIA

Over 200 years old, the “Pležuh” from Selnica originally consisted of a curved barrel stave and had a distinctively low seating position.

USA

Woodcutters used “Jack Jumpers” (Böckl) to get down to the valley quickly after work.



An entrepreneur with passion and vision

GRANDPA FRANZ
(*02.07.1932 †10.02.2004)

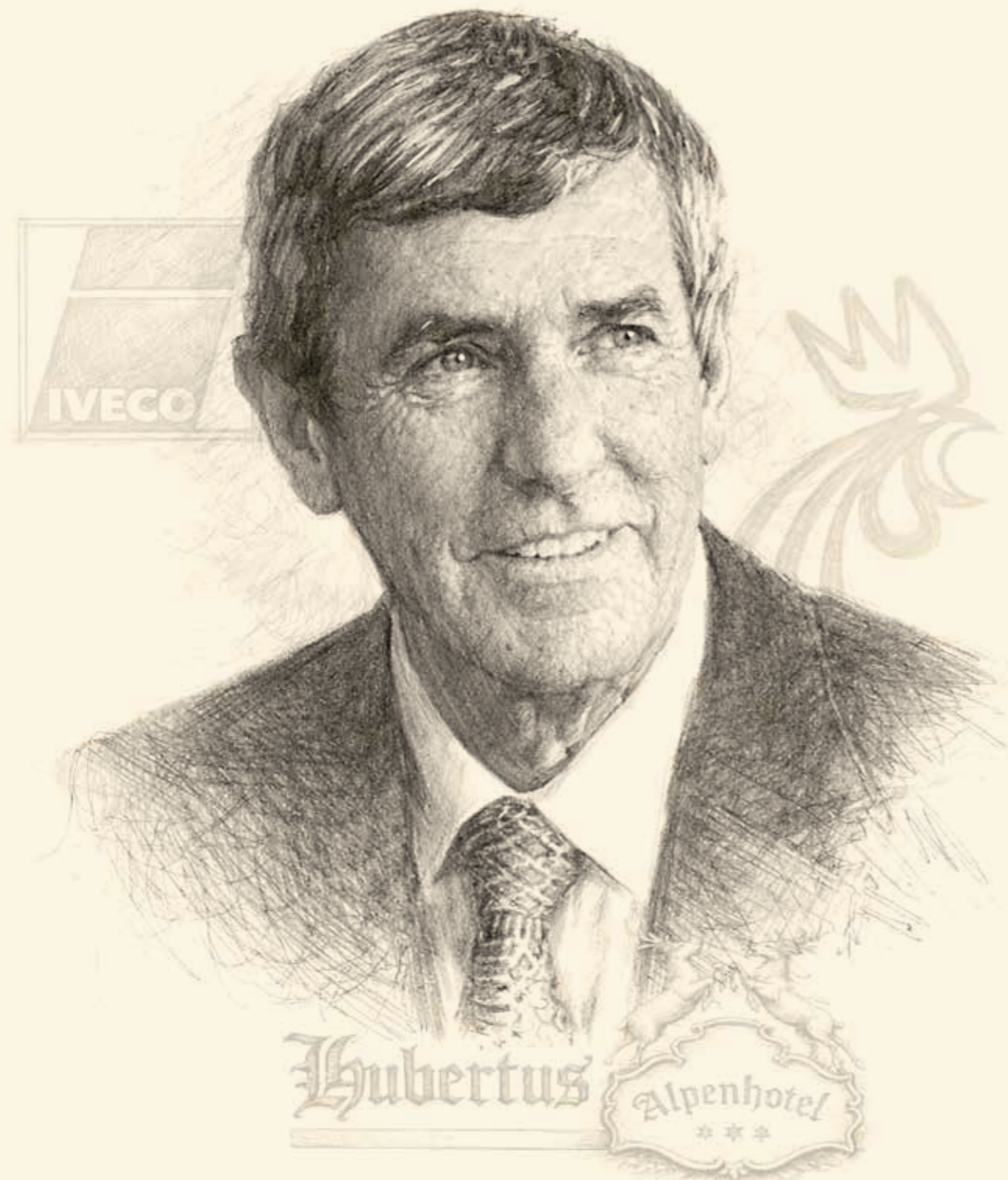

Franz Gasser was much more than a car dealer; he invested in people and created places for future generations.

From an early age, Franz Gasser was drawn from the lively provincial capital of Bozen to the tranquil surroundings of the Pustertal Valley. There he put down roots and left a lasting mark. What had begun as a new start developed into a life's work that continues to have an impact to this day. With a sure instinct for the right moment and a constant closeness to his adopted home, he built up a business, step by step. The essentials always remained equally important: not just success, but above all the people and projects of the Pustertal Valley. His companions still remember his proverbial trustworthiness, a virtue that he also passed on to his children.

Pepi Moser remembers

Now in his late 70s, Pepi Moser still often sits in his office at the car dealership of the same name in Bruneck, now run by one of his sons. Pepi is a living encyclopaedia, remembering the past as if it were yesterday. Speaking of the past, Pepi points to an old office cabinet and says with a smile, "This is the very cabinet that Franz Gasser had in his office back then." He then begins to tell the story of how Franz Gasser came to Bruneck.

How it all began

"It was back in 1955", says Moser. "My father, Josef, was a freight forwarder on the railways in Bruneck, delivering the goods arriving by rail to the local businesses and shops. One day, he was offered the chance to take over the distribution of Fiat vehicles in the Pustertal Valley. My father knew very little about motor vehicles at the time, but he recognised their potential and looked for someone with the right expertise."

The search led him to a young salesman from Bozen: Franz Gasser, a successful salesman of Vespa scooters and tricycles, who came from a 13-strong family of winegrowers from St. Georgen, near Bozen: the Kofler auf Ceslar winery, which is still producing wine today. At the age of just 23, he moved to the tranquil city of Bruneck, bucking the trend of people moving from the countryside to the city.

"My father quickly realised that this young man had a natural talent for sales", continues Moser.

"My father quickly realised that this young man had a natural talent for sales", Moser recounts. Together they opened the Garage Dolomit in Bruneck. Josef Moser remained largely in the freight business, while Franz Gasser took over the car dealership.

“I was seven years old at the time”, recalls Pepi Moser. “When I once heard Franz’s father, Georg Gasser, say to his son Franz and my father, ‘Don’t ever argue’, I knew how serious he was. We never argued in our family and we never needed legal assistance.” Franz was tall, charismatic and was seen as very likeable. Selling cars was still in its pioneering stage at the time; customers did not simply come to you – you had to go to them. It often took several visits to close a deal. Franz had his own strategy: he would gather information at service stations, asking the petrol pump attendants which were the most popular cars on the road and who might be interested in a new model. He then targeted these specific customers. In the early years of their marriage, his wife Heidi would often accompany Franz to the most remote mountain valleys. While he negotiated sales, she waited patiently in the car with a book in her hand. These trips also represented the young couple’s weekend getaways.



PEPI MOSER

Franz Josef “Pepi” Moser, born in Bruneck in 1948, was a business partner who worked closely with Franz Gasser for many years. Having worked his entire life in the car trade, he now looks back on a shared journey full of entrepreneurial milestones; he vividly remembers the early days of the car dealership and Franz Gasser as a person.

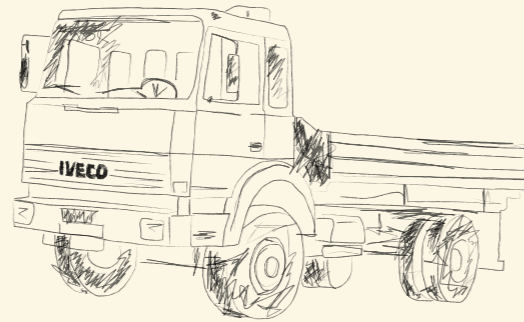

Franz Gasser initially traded in commercial vehicles, laying the foundations for new business ventures.

New paths

Franz was a born salesman, full of energy, charisma and business instinct. Moser, on the other hand, was more a quiet type, responsible for organisation. After over 25 years, their business paths diverged: Moser continued to run the passenger car division, while Gasser concentrated on commercial vehicles.

Moser continued to run the passenger car division, while Gasser concentrated on commercial vehicles.

The Fiat Group had also correspondingly split into two divisions: Fiat Veicoli for passenger cars, with Iveco for industrial and commercial vehicles. Franz recognised opportunities far beyond the car trade. He invested in a local company that was about to expand: he later withdrew from the venture, securing capital for new projects.

A key project in which Franz Gasser played a major role and which laid the foundations for the sustainable development of Kronplatz and the entire region.

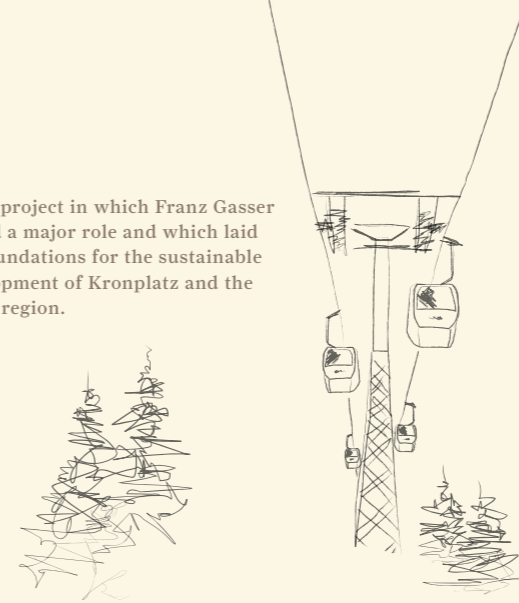

The biggest project of all: the Kronplatz cable car company

In addition to expanding Gasser Iveco, his commercial vehicle company, Franz’s most important project was the cable car company, Kronplatz Seilbahn AG. Werner Schönhuber, who served for 36 years as company chairman of Kronplatz Seilbahn AG, recalls the early days. Modest as ever, Schönhuber does not put the spotlight on himself. But one thing is clear: “The history of Kronplatz AG is inextricably linked to Franz Gasser.”

“The history of Kronplatz AG is inextricably linked to Franz Gasser.”

On 25 December 1963, the cable car running from Reischach up to the summit began operation, together with a ski lift on the mountain. Things were difficult at the outset, however, and by 1964 the company was on the brink of collapse. The capacity – just 350 people an hour on the lower section and 450 people from the middle station – was not enough to ensure economic viability.

In 1982 and 1983, the first major maintenance work was due, but the coffers were empty. Salaries could no longer be paid and the company was on the brink of collapse. In 1983, Schönhuber took over as chairman and desperately searched for solutions. Despite the high risk involved, a share issue was supposed to offer salvation, but a considerable financial hole remained. At this crucial moment, Franz Gasser intervened: in a remarkable show of courage, he subscribed the remainder of the shares. This

intervention not only saved the company, but also the capital belonging to many small shareholders – and laid the foundations for the survival of Kronplatz. It would not have been possible to finance a new cable car at that time, so the existing cable car was instead completely overhauled and augmented by a double chairlift and a ski lift. Transport capacity increased; waiting times were reduced and, step by step, the company achieved stability. With Franz Gasser now on the board of directors, a vision and a motto emerged: “If we are to do it, let’s do it right”. The winter of 1986-87 saw the Kronplatz I and Kronplatz II cable cars, among the most modern and efficient in the world, begin operation. As Schönhuber states: “You mustn’t dare to imagine what would have happened if this venture had failed back then.” “For twenty years Franz Gasser waived the dividends to which he was entitled. That was a huge help in enabling the company to develop.” He adds: “Franz knew that a functioning cable car on Kronplatz was so much more than a tourism project; it is a supporting structure for the entire region, a basis for prosperity and employment for everyone who lives around the mountain.”



WERNER SCHÖNHUBER

Werner Schönhuber, born in 1943, was chairman of Kronplatz Seilbahn AG for 36 years and played a decisive role in shaping its development. At the same time, he led his family business – Sportmode Schönhuber – to remarkable success, with five stores in Bruneck, Kronplatz and St. Vigil. His name is a byword for entrepreneurial drive and deep regional ties.



The origins: from the little Höhenrain guesthouse to the Hotel Hubertus.

Work, family and hunting

Franz had clear priorities: work, usually well over 48 hours a week; family; and hunting, his great passion. And, so as to be able to approach his hobby a little more closely, Franz built himself a simple hut high up on Kronplatz, without either a shower or heating: just a wood-burning stove for cooking and warmth. In summer the family would spend weeks up at the hut on holiday. During the week, his wife Heidi looked after the children while Franz went to work. At the weekend, he returned to the hut. Holidays for Franz meant roaming the forests, observing the wildlife, hunting and spending time with his family.



A simple retreat. For many years, the little wooden hut on Kronplatz was where the family would spend the summer months.

Hubertus – a longed-for place

Another important place in Gasser's life was the little Höhenrain guesthouse in Geiselsberg. On his way down to Bruneck from the hut at Kronplatz, he often stopped there to enjoy the view of Olang from its terrace and gaze at the mountains beyond. The panorama reminded him of Bozen, his hometown. He would often say: "Down below is the town, beyond are the Dolomites". When one day the guesthouse was put up for sale, Franz thought of it as more than just a private retreat: what counted for him was the long-term benefit for the next generations. He bought the property, naming it after Hubert, the patron saint of hunters, and leased it out for many years.

Franz handed over the establishment to his eldest son Christian with the words: "Make something of it".

He finally handed over the establishment, which was now showing its age, to his eldest son Christian, then just 22 years old, with the words: "Make something of it".

A living inheritance

Today, Franz Gasser would be both proud and humbled if he could see what has become of his legacy. Under the guidance of Christian and Helga, the original 30-bed guesthouse is these days a well-established hotel in the South Tyrolean accommodation sector. Their two children, Daniela and Markus, now run the business and have developed it into an internationally recognised wellness retreat.



Christian and Helga Gasser. At the age of just 22, he took over the hotel together with his wife. With plenty of hard work, courage and dedication, they turned it into one of the region's leading hotel retreats. Today, their two children, Daniela and Markus, are continuing with this success story.

Wellness between blue skies and comfort

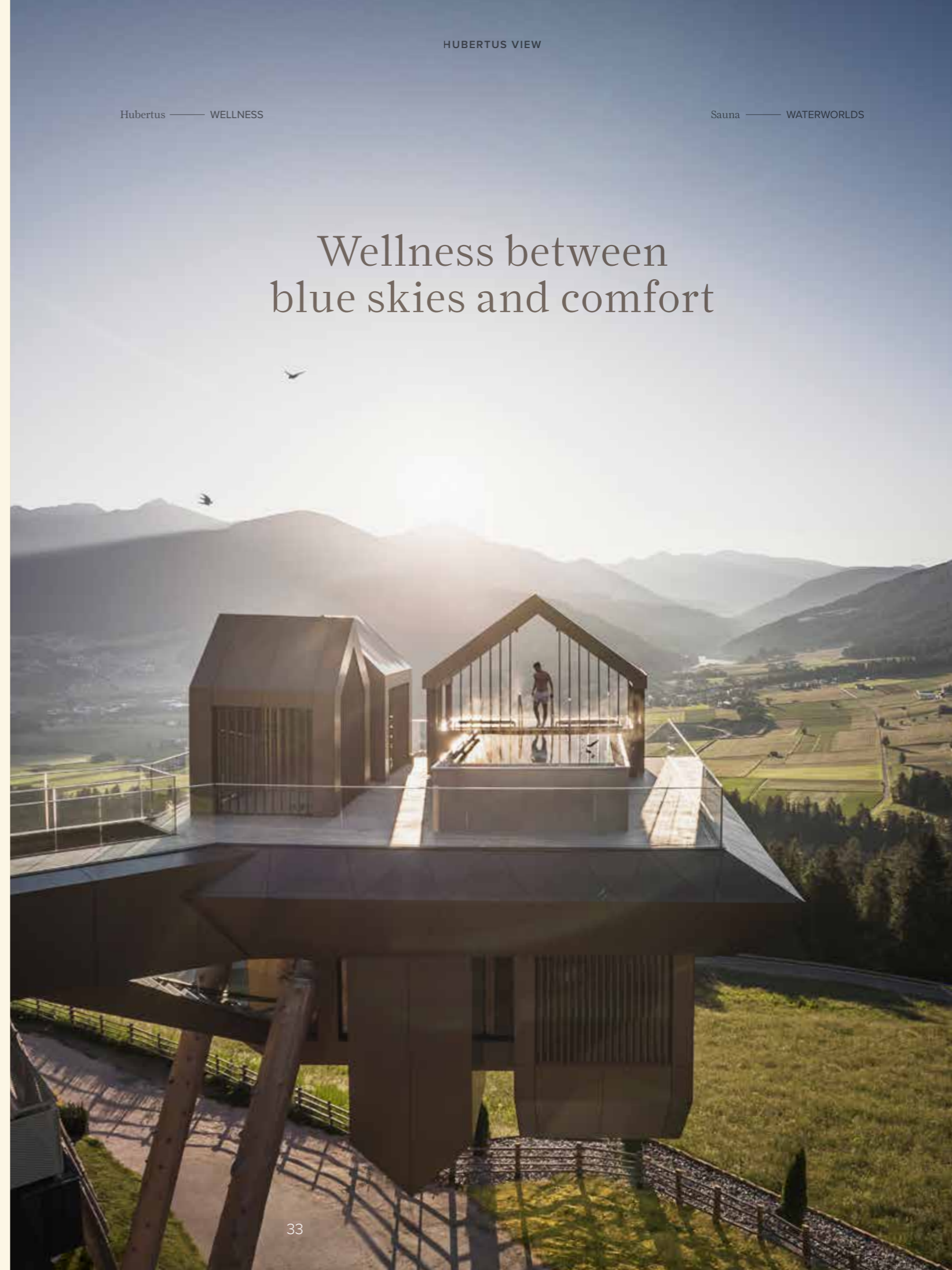



HEAVEN & HELL SKY SPA

A wellness area on two levels, featuring exceptional architecture, two saunas and three hot tubs, all overlooking the valley.

Floating above the valley, the pool opens up to the vastness of the landscape.

Architecture and nature here merge to create a special form of well-being. The Sky Spa Heaven & Hell offers a panorama that goes far beyond the ordinary: located on two levels, its two saunas and three soothing hot tubs invite guests to relax. In the upper area, water and mountain air combine to create a feeling of lightness while, in the lower area, warmth and a feeling of ease will release new energy. These moments of quiet are accompanied by the spectacular view that, thanks to the large glass surfaces and wide perspectives, almost becomes part of the landscape itself. Wellness here is thus not merely relaxation for the body, but an experience that will engage every single one of the senses.



Architecture with a view: clear lines nestling amidst the mountains.





Comfortable loungers in the spacious relaxation park with views of the mountains.



A variety of water worlds, from hot tub to Sky Pool, in a sunny, panoramic location.



HUBERTUS VIEW

Sky Pool with sweeping views over the valley.



A tranquil wellness world with warm materials and clear design.



A place to regain energy – reimagined.





**SKY POOL:
FEEL THE POWER
OF WATER**

Water and nature merge in the Sky Pool to create a unique experience. Swim, enjoy the surroundings and feel your energy levels rise.

Freedom, exercise and relaxation all combine to create a holistic experience of well-being. The water world, with its Sky Pool, new indoor pool, saltwater floating pool, outdoor cold water pool and several outdoor hot tubs, offers spectacular views of the surrounding landscape. Atmospheric quiet rooms and the redesigned terrace invite you to stay a while; the fitness area creates space for new energy; the treatments provide a deep tranquillity. Every detail here becomes part of your personal well-being.



Well-being in space, movement and tranquillity

ALPENREYCH SPA – POWER & BALANCE

Massages, alpine herbal applications and exclusive treatments combine the power of nature with a soothing touch – for deep relaxation, renewed energy and lasting well-being.



Modern fitness centre with mountain views.



Relaxing treatments in a peaceful atmosphere.

A life between forests, mountain pastures and well-being

SONJA, THE REFRESHING SOUL OF THE HUBERTUS

You are almost certain to meet Sonja if you visit the Hubertus: she accompanies our guests on trips into the mountains, goes with them on forest bathing outings or will start the day with gentle morning exercises. She offers more than mere expertise; she lives her connection with nature and the region.

“You always meet twice in life”, she says with a smile that reveals that this phrase is more than just a saying for her: because many things in life return, sometimes in a different form, but always familiar. Places, encounters and situations reappear and, because we have changed, we experience them with different eyes, hear them with different ears and feel them with a more mature heart. Sonja’s childhood was marked by simplicity and living in the great outdoors – not out of conviction, but because of circumstances. Money was tight, so a family Sunday meant hiking up to the mountain pastures, with a picnic lunch and refreshment provided by the spring along the way. As for sweets, these were not from the shop but from the forest: a handful of raspberries, wild strawberries or blueberries – straight from the bush, warmed by the sun and sweeter than any chocolate. The family also gathered mushrooms, which were considered part of the fare rather than a delicacy.

“And my father knew every plant”, says Sonja. “He knew which ones helped against fever, which ones calmed the stomach or aided sleep.

His medicine cabinet grew outside his front door, while knowledge was passed down from generation to generation, inaudibly and as a matter of course.” “When I think back on it, I see it with different eyes. What at the time was scarcity was in fact riches, something that I only realised much later.” Sonja now loves the forest and no longer enters it reluctantly, as she once did in her youth, but with her heart and eyes all wide open. “What was once a duty is now a calling. And what I didn’t appreciate back then is now what is most precious to me: namely simplicity, naturalness, the connection to the earth.”

“What at the time seemed like scarcity was in fact riches, something that I only realised later.”

Between nature and people – her special calling.



Forest bathing: a place of silence, a source of strength and a home for thoughts. Here, time slows down and the essentials become tangible

Nowadays, she accompanies guests on forest walks, telling them about the herbs along the way, the scent of fresh hay, the songs of the birds, the power that lies in trees and plants. Even as a child, she said to her mother: “Olang is so beautiful, I want to live here forever.” And she in fact never gave up on her wish. At fourteen and a half, Sonja began an apprenticeship as a hairdresser near where she lived at the time. She was young but determined and, while work was important to her, her desire to have a family was even stronger. At fifteen, she met her partner, Georg: she got married at eighteen and became a mother for the first time at twenty, giving birth to a daughter, Kathrin. Two more children, Elisa and Tommi, followed. “If it had been up to me, I would have liked to have had five. I always wanted a big family, with lots of life, warmth and love, where everyone would get along well together.” The time following the birth of her first daughter was difficult for Sonja: there were simply no opportunities for part-time working then, as people either worked full-time or not at all. Thus, after just three months, Sonja had to go back to working full-time.



A mindful touch: hands that feel the forest and calm the mind.

“Olang is so beautiful.
I want to live here forever.”

Her mother took care of her daughter in the mornings, with her husband taking over in the afternoons. Although Sonja knew that her daughter was in good hands, she sorely missed spending time with her. “I would have liked to have been closer to her, to have spent more time with her each day, to have been more of a mother to her”, she now says. Today, Sonja is a grandmother. Emil, her grandson, is a great gift to her. And, when Sonja looks back on her past, she is filled with a deep gratitude.

More to herself with every step

Over the years, Sonja felt ever more strongly that she wanted to return to nature. Alongside her work in the restaurant trade, she began a series of training courses: massage, Pilates, aqua gym, Nordic walking, sauna fragrances. At a certain point she started working at the Hotel Hubertus, at first as a freelance masseuse. When she was offered the chance to work all year round as a wellness trainer and hiking guide, she immediately knew: “This is the path for me.”



A break with Sonja at a mountain hut to enjoy, laugh and arrive together: lunch in the best of company.

Sonja is proof that relaxation can be fun too. And anyone who thinks they know her is sure to be surprised by her routine in the sauna!

A day to combine activity and relaxation

Sonja accompanies guests through the week with a programme that varies between activity and relaxation: from morning exercises and scenic hikes in the surrounding mountains to meditative forest bathing. Then, to round off the day, there is an evening sauna session with special fragrances introduced into the steam.

But anyone who might think this is always a quiet, solemn business is mistaken. A sauna session led by Sonja can become lively, sometimes even a little wild. Her South Tyrolean temperament, wit and energy all bring movement into the room.

“The best thing about my work”, says Sonja, “is when I get to see how people change over the course of a few days. A guest can arrive at the hotel, hectic and stressed: then, gradually, they find peace. Once serenity returns and their inner radiance becomes visible, I know that I’m exactly where I’m meant to be.”



After an eventful day, it’s off to the sauna, where Sonja literally becomes the “dancing queen”.

A workplace above the clouds

Some workplaces are just that – a place. And then there are those that each day remind you why you love what you do. For Thina Adams, director of the LUMEN Museum of Mountain Photography, childhood memories come flooding back at the summit of Kronplatz, when the mountain was her second home, for hiking in summer and skiing in winter.

SHORT FACTS

LUMEN – MUSEUM OF MOUNTAIN PHOTOGRAPHY

LOCATION: Kronplatz

ALTITUDE: 2,275 m

THEME: Mountain photography, from historic pioneering images to contemporary photographic art

DISTINCTIVE FEATURE: panoramic architecture, special exhibitions



It is always a special moment for Thina Adams when she takes the cable car in the morning, as everyday life down in the valley recedes ever further into the distance. She no longer sees Kronplatz as she used to, as just a mountain for sports and leisure activities; it has long since also become a cultural summit for her. A place of vastness, she says, with LUMEN a place of perspective. Here, at 2,275 metres above sea level, photography becomes a language with which the mountains can be described: emotional, critical and at the same time fascinating. Light, panorama and visual art between them transform culture on the mountain into a true experience. LUMEN turns photography into a window on the past and, simultaneously, a mirror of our present. And

Light, panorama and visual art transform culture on the mountain into a true experience.

while outside the peaks stand in silent grandeur, within it becomes clear how people have always viewed the mountains: as a place of longing, as a challenge, as beauty and as home.



WALL OF FAME

At the very start LUMEN pays tribute to the pioneers of mountain photography: people who climbed peaks with heavy equipment to create images that were technically almost impossible at the time. "These photographers weren't just artists", says Adams, "they were adventurers. Every picture was an achievement, sometimes almost an expedition."

MOUNTAIN MANIA

Another highlight illustrates how photography turned mountains into icons. Picture postcards made mountain motifs accessible to the masses; images became the driving force behind tourism. "Many of our ideas about what mountains mean to us are strongly influenced by images", says Adams.

ROOM OF MIRRORS

The Room of Mirrors is both poetic and atmospheric. Here, the focus is less on the motif and more on the feeling. "This room is like an emotion", Adams says. "It doesn't show the mountains as they are, but rather how they affect us."



A journey on four floors: through time and the history of mountain photography.

From top station to museum

High up on Kronplatz, at an altitude of 2,275 metres, can be found a museum that is unrivalled in Europe. Over four floors, covering around 1,800 square metres of exhibition space, it takes visitors on a visual journey that widens and deepens their view of the mountains. Its creation was extraordinary: LUMEN was not a new build, but instead grew from an existing structure. It is located in the former top station of the cable car, with a history dating back to the 1960s. Its conversion and cultural reinterpretation symbolise the concept behind the building. Officially opened in 2018, the museum has since formed part of a development in which the mountain is increasingly seen as a centre of culture. The view of the mountains is no mere backdrop, but a deliberate part of the experience. "It's not just a question of looking at images", explains Adams. "It's about honing your own vision and understanding why mountains have always been able to move us."

THE SHUTTER

A movable camera shutter at the former entrance to the cable car has come to symbolise the building. When it is closed, a film is projected; when open, the view extends out into the Dolomites. "For me, this is one of the most impressive experiences up here", says Adams. "You switch between image and reality. That's exactly what LUMEN is all about."

CONTEMPORARY MOUNTAIN PHOTOGRAPHY

Large-format photographs by international photographers not only show beauty, but also raise questions about change, nature and presentation. "The mountains are not only beautiful", Adams emphasises. "They are also a mirror of our times."



A region that will move you

EXPLORING THE PUSTERTAL VALLEY ON TWO WHEELS



The Pustertal Valley and Kronplatz combine enjoyable cycling in the valley with scenic mountain tours and exciting trails, offering space for relaxation, sporting challenges and quiet moments in the great outdoors.

The Pustertal Valley and Kronplatz are among those regions where cycling can become a real way of life. Between the wide valley floors and imposing peaks, a landscape opens up that is made for exploring on two wheels. It is not just a matter of distance travelled or height gained, but about the experience, as you immerse yourself in nature, mindful of your surroundings. Down in the valley, well-maintained cycle paths wind their way through meadows, forests and small villages. Two rivers, the Rienz and later the Drau, often flow alongside the route, gently babbling and always in motion. Cycling is pleasant, clear and varied: whether on a leisurely family outing, a relaxing ride for pleasure or a more sporting day trip, everyone can find their right pace in the Pustertal Valley.



Cycling opens up new perspectives. Enjoy tours through the Pustertal Valley, to Cortina or to neighbouring Lienz in Austria.

CYCLE TOURS STARTING FROM OLANG

- 1 **KRONPLATZ** ⚡ summit | 15 km | 4 hrs
- 2 **KRONPLATZ ROUND** Olang – Furlkelpass – Enneberg – Maria Saalen – Bruneck – Olang ⚡ | 41 km | 4–5 hrs
- 3 **TAUFERER AHRNTAL VALLEY** ⚡ Sand in Taufers | 37 km | 3–4 hrs
- 4 **ANTHOLZERTAL VALLEY** ⚡ Lake Antholz | 42,7 km | 3 hrs 40 min.
- 5 **GSIESERTAL VALLEY** ⚡ Talschluss Hut | 24,8 km | 2 hrs 43 min.
- 6 **CORTINA D'AMPEZZO** ⚡ centre | 49,8 km | 5 hrs 5 min.
- 7 **SEXTEN** ⚡ centre 30,3 km | 2 hrs 10 min.
- 8 **LIENZ** ⚡ centre 50 km | 2,5–3,5 hrs

Times and distances are for guidance only.



The heart of the region is the Pustertal Valley Cycle Path, which runs along the entire valley. Its gentle gradients make the route ideal for long tours without requiring excessive effort. Many cyclists particularly appreciate the flexibility of being able to plan individual sections and tailor their tours to their individual preferences and fitness levels.

Those wishing to go even further can cycle from Innichen and across the Austrian border to Lienz in East Tyrol. This stage is particularly popular as it is mostly easy and offers impressive scenery. The return journey can easily be done by train, giving you additional freedom when planning your tour.



Pause for a moment. Take time to linger and gaze over the mountains.

Tranquil, unspoilt side valleys

The many attractions of the Pustertal Valley include its numerous side valleys, which open up like little worlds of their own. From Bruneck, a well-signposted cycle path leads to the Tauferer Ahrntal Valley. The route is initially flat and leisurely, but subsequently becomes more challenging as it leads deeper into an alpine landscape that becomes more unspoilt with every bend.

The Upper Pustertal Valley also offers a wide range of possibilities: varied routes around Toblach and Innichen offer magnificent views of the Sexten Dolomites, while a particularly delightful tour leads along the former railway line towards Cortina, nowadays a popular cycle path that wonderfully combines enjoyment, history and panoramic views.

Those seeking peace and quiet will find an idyllic route up to the end of the Gsiesertal Valley, running past the stream that flows in the opposite direction. Equally charming is the Antholztal Valley, where a pleasant cycle path along the valley floor ultimately provides a scenic section leading up to Lake Antholz. Both valleys are noteworthy for their abundance of nature, tranquillity and impressive landscapes.

Explore new horizons by e-bike

E-bikes open up whole new possibilities in the Pustertal Valley. Routes that would only have been conceivable as long day hikes can now be enjoyed on two wheels. Steep climbs lose their terror; longer distances can be covered with ease.

The beauty of it all is that it is not just a question of reaching a destination, but of experiencing an entire landscape in between. Many people enjoy cycling here as a kind of panoramic journey, coasting through valleys, rolling through forests, crossing mountain pastures and discovering new views, over and over again – with plenty of time to stop, marvel and savour it all.

Kronplatz and the mountain world

Then there are the mountains around Kronplatz, where cycling is more of an alpine, athletic and adventurous activity. In addition to the classic tours along forest paths and mountain roads, there are numerous opportunities to explore the high mountains on two wheels.

A particular highlight is the Kronplatz Bike Park with its multiple trails: routes range from smooth and leisurely to technically demanding. Many of the starting points are easily accessible by cable car, making it a relatively painless experience and leaving you with more energy for the descent, for corners, for riding fun and for that special feeling of freedom.

For beginners, there are panoramic tours and easier routes where the focus is more on enjoying the landscape, while experienced riders can find more challenging trails featuring tree roots, steeper sections and a variety of terrain, all making Kronplatz a meeting place for cyclists of all kinds.



Aim for the sky on two wheels and see new horizons open up.

Belvita

LEADING WELLNESSHOTELS
SÜDTIROL



Life in motion

With an exceptional outdoor and activity programme, the “Belvita Active” hotels provide the perfect setting for an active holiday that is sure to impress – with guided tours, free equipment rental, and much more.

As a member of the Belvita Leading Wellnesshotels Südtirol, this hotel guarantees the highest quality in all areas.



belvita.it



Visit us on Facebook:
www.facebook.com/hotelhubertus



Visit us on Instagram:
[hotel_hubertus](https://www.instagram.com/hotel_hubertus)



HUBERTUS

Gasser Touristik GmbH

The Gasser Family · Furkelstraße 5 · I-39030 Geiselsberg-Olang · South Tyrol

Tel. +39 0474 592 104 · Fax +39 0474 592 114 · info@hotel-hubertus.com

www.hotel-hubertus.com

